

### FRIGOMATIC CAPRI 50-SSC

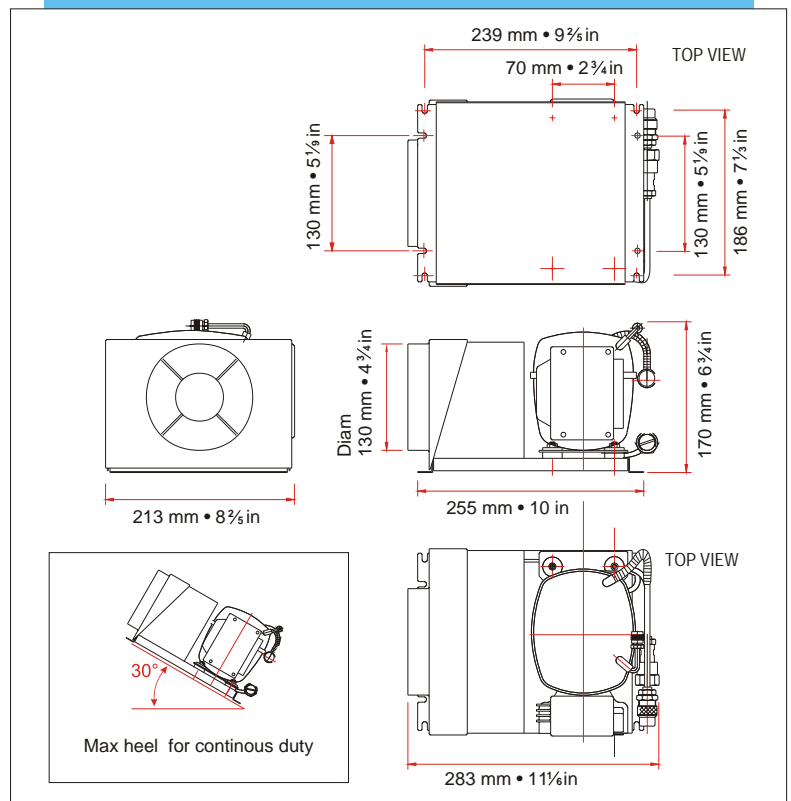

Part N. E52120

- Danfoss compressor of the latest generation.
- Extremely compact dimensions.
- Maximum efficiency.
- Danfoss BD50 compressor with electrical consumption 25% lower than earlier compressor concepts.
- Equipped with Smart Speed Control.
- Forced air cooling.
- Precharged system with Frigoboat self sealing couplings.
- Configurations with evaporators for fridges up to 15 cu.ft. and freezer up to 5 cu.ft.
- Automatically runs on 12 or 24 volts.
- Automatic battery protection.
- Equipped with a fan shroud which allows the warm air to be exhausted from a restricted area with poor ventilation.



# FRIGOMATIC CAPRI 50-SSC

### SYSTEM CONFIGURATION

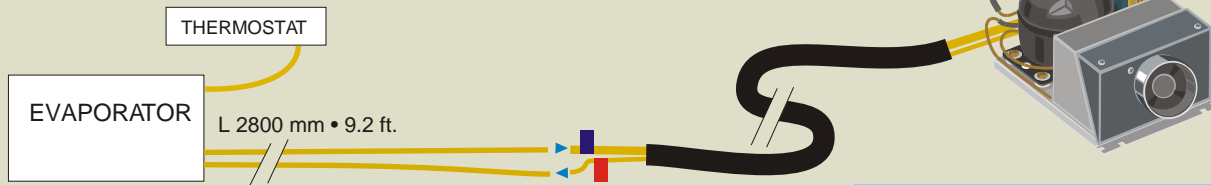

### TECHNICAL CHARACTERISTICS\*

COMPRESSOR SPEED	2000	2300	2600	2900	3200	3500
CAPACITY BTU/H	332	360	403	431	453	500
CONSUMPTION (A/12V)	3.8	4.3	4.8	5.2	5.7	6.2

WEIGHT 12.7 lbs. 5.8 Kg  
 SHIPPING WEIGHT 14.5 lbs. 6.6 Kg

\*Under Average Conditions

### PRECHARGED EXTENSIONS (Options)

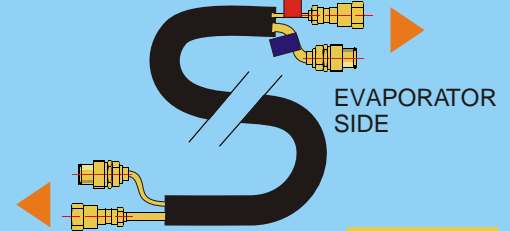

COMPRESSOR SIDE	L	Part N..
	1m • 3ft	E50255
	2m • 6ft	E50260
	3m • 10ft	E50265

## The Smart Speed Control

Part N. E52150

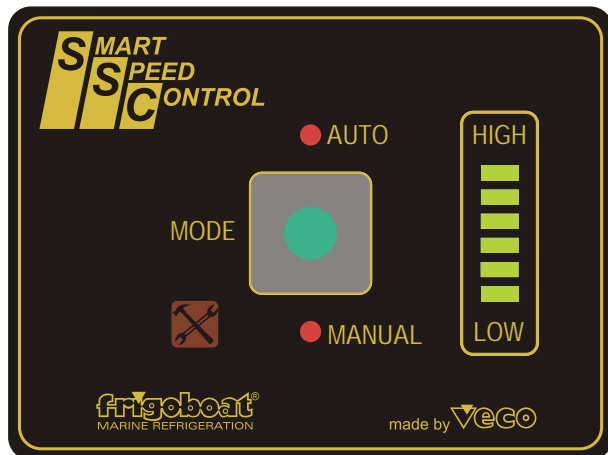

ACTUAL SIZE

### Featuring:

- Compressor Protection.
- Automatic Speed Adjustment for Maximum Operating Efficiency.
- Manual High Speed Reset Feature (for icebox restocking).
- Many other features, see brochure for details.

### THERMOSTAT



FRIDGE  
Part N. E250500



DOUBLE  
Part N. E261300



SPILOVER FAN & THERMOSTAT  
Part N. E26200

Manufactured in Italy by

Distributed in the USA & Caribbean by:  
Coastal Climate Control, Inc. Annapolis MD USA

frigoboat.com